

SINOPEC *Lubricants*



Dual wear resistance

Traffic congestion, sudden turns, muddy roads
Increase the tenacity and intensity of lubricating oil film for super-strong wear resistance

**Silent and smooth
Ultimate protection**



Efficient cleaning



Viscosity controlling

Extreme cold and hot days
Change molecule intervals for easy initiation

JUSTAR
Engine oil



In **2016** SINOPEC ranked the **4rd**

In Fortune **500**

World's fourth largest lubricant company, **largest** in Asia



Brief Introduction

Sinopec Lubricant Co., LTD.(Sinopec Lubricant Company. for short), a subsidiary of China Petroleum & Chemical Corporation (SINOPEC Corp.), one of the world's top 500 enterprises, is a professional lubricant company which integrates production, R&D, storage, distribution, service, etc. in all its business.

The company's products mainly include engine oils, gear oils, hydraulic oils, greases, marine oils and so on. The products are widely applied in various fields such as aviation, aerospace, automotive, machinery, metallurgy, mining, petrochemical industry and electronics. In particular, SINOPEC marine lubricants have been used on VLCC and is appointed for using by the XUELONG, the only polar research ship in China. The company has good relationship with the four main Chinese shipping groups- COSCO, China Shipping, Nanjing Tanker and CMHK.

In order to keep the advancement of product quality, and protect environment, SINOPEC Lubricant Company has achieved Certificates of ISO9001, QS9000 and TS16949 quality assurance systems, as well as HSE (Occupational Health, Safety & Environment) system. Products of SINOPEC Lubricant Company not only meet the requirements of national standards, but also fulfill the demands of many other special requirements of ISO (International Standard Organization), API (American Petroleum Institute), ACEA (European Automobile Manufacturers Association), etc. SINOPEC Lubricant products are qualified by world famous marine diesel engine manufacturers and granted with corresponding certificates.

Devoted to development of Chinese lubricant requirements, Sinopec Lubricant Company has actively participated in international competitions and made efforts in seeking long-term cooperative relationship with related industries to achieve mutual development and advancement.

Lubricating protection specially for space flight

Every journey is filled with expectation
Every beginning is free and relaxed
Every increase in velocity is filled with excitement
Sinopec sedan engine oil is sourced from lubrication technologies specially designed for space flight. With unique additives and formula technologies, it enables precise balance and maintenance targeted at different components, temperatures and resultants, thus making your engine powerful and inspiring ultimate potential!



JUSTAR

Engine oil

JUSTAR J700



JUSTAR J600



JUSTAR J500



**JUSTAR J700U
0W-50**

**JUSTAR J700F
PREMIUM
0W-40**

**JUSTAR J700F
PLUS
5W-30**

**JUSTAR J700F
5W-40**

**JUSTAR J700F
5W-30
5W-20**

**JUSTAR J500
SM/GF-4 10W-30
SM/CF 10W-40**

**JUSTAR J500
SM/CF 15W-40
SM/CF 20W-50**

**JUSTAR J500
SL/CF 20W-50**

**JUSTAR J600F
PREMIUM
5W-40**

**JUSTAR J600
PREMIUM
10W-40**

**JUSTAR J600
5W-30**

**JUSTAR J600
10W-30**

24-29

16-23

06-15

JUSTAR J700U

0W-50
Engine Oil

API SN/CF
Ultra Synthetic



Product description

SINOPEC JUSTAR J700U 0W-50 Engine Oil is a super-premium product formulated with ultra high performance fully synthetic base oils (PAOs) and advanced high-quality multifunctional additive technology. It provides excellent oxidation resistance, deposit and wear protection, coupled with low-temperature performance for service in a wide range of high-performance automotive petrol engines, and light-duty diesel engines. It is particularly suitable for high-speed applications and the severe service conditions associated with stop-start driving.

Applications

SINOPEC JUSTAR J700U 0W-50 Engine Oil is suitable for use in:

- Latest fuel-injected, turbocharged and supercharged petrol engines.
- Ultimate performance petrol engines in passenger cars, racing cars and coaches.
- Turbocharged, intercooled, direct-injection light-duty diesel engines fitted to vans and light commercial vehicles.
- Also suitable for older model passenger cars and vans where a top performance oil is required.

Features and benefits

- The combination of fully synthetic base oils (PAOs) and advanced additive technology inhibits the formation of engine sludge, reducing oil thickening, thereby keeping the product in grade for longer, extending oil life and allowing longer oil drain intervals.
- Very low oil evaporation loss leads to reduced oil consumption and reduced exhaust emissions.
- Excellent antiwear performance protects against engine wear and prolongs engine service life.
- Wide oil viscosity range protects engine parts operating at both high and low temperatures.
- Excellent high-temperature, high-shear properties ensure oil viscosity is maintained under severe service conditions, protecting the engine from wear.
- Good elastomer compatibility ensures longer gasket and seal life, and prevents oil leakage.



Typical data

SINOPEC JUSTAR J700U 0W-50 Engine Oil

SAE grade	0W-50
Kinematic viscosity, ASTM D 445	
cSt@ 100°C	17.61
Dynamic viscosity, CCS, ASTM D 5293	
cP@ -35°C	6190
High-temperature, high-shear viscosity (HTHS), ASTM D 4683	
cP@ 150°C	4.5
NOACK volatility, ASTM D 5800	11
Total base number, mg KOH/g, ASTM D 2896	8.4
Pour point, °C, ASTM D 97	-50
Flash point (COC), °C, ASTM D 92	232
Density@ 20°C, kg/l, ASTM D 4052	0.841

These data are given as an indication of typical values and not as exact specifications.

Industry and OEM specifications

API Service Classification	Petrol/Gasoline: SN, SM and earlier specifications
	Diesel: CF and earlier HDDEO specifications
Audi	Suitable for use in Audi 8 series
BMW	Suitable for use in BMW 7 series
Mercedes Benz	Suitable for use in Mercedes Benz S class

JUSTAR J700F *Premium*

0W-40

Engine Oil

API SN/CF

Fully Synthetic

VW 505 00/ 502 00 Approved

ACEA A3/B4



Product description

SINOPEC JUSTAR J700F Premium 0W-40 Engine Oil is a premium product formulated with super high performance fully synthetic base oils and high-quality multifunctional additive technology. It provides excellent oxidation resistance, deposit and wear protection, coupled with low-temperature performance for service in a wide range of modern, high-performance petrol and light duty diesel-powered vehicles.

Applications

SINOPEC JUSTAR J700F Premium 0W-40 Engine Oil is suitable for use in:

- Luxury European cars, such as Porsche, BMW, Benz, Volkswagen, Renault, etc.
- High-performance passenger cars, racing cars and coaches equipped with or without multi-valves, variable valve timing, turbochargers and direct-injection engines.
- Engines requiring oils with A3/B4 grade.

Features and benefits

- High performance fully synthetic formulation keeping the product in grade for longer, extending oil life and allowing longer oil drain intervals, lasting protection and power for GDI engines with or without turbochargers.
- Excellent start up performance at low temperature and lubricating properties at high temperature, suitable for different regions and all weather use.
- Excellent anti wear performance, reducing wear effectively to extend engine life.
- Superior oxidation stability and cleaning power to prevent deposits and sludge build-up, and extend oil drain intervals.





Typical data

SINOPEC JUSTAR J700F Premium 0W-40 Engine Oil

SAE grade	0W-40
Kinematic viscosity, ASTM D 445	
cSt @ 100°C	14.47
Dynamic viscosity, CCS, ASTM D 5293	
cP @ -35°C	5,800
Mini-rotary viscometer (MRV), ASTM D 4684	
cP @ -40°C	30,800
High-temperature, high-shear viscosity (HTHS), ASTM D 4683	
cP @ 150°C	3.78
NOACK volatility, ASTM D 5800	9.7
Sulfated ash, wt%, ASTM D 874	1.03
Total base number, mg KOH/g, ASTM D 2896	10.2

These data are given as an indication of typical values and not as exact specifications.

Industry and OEM specifications

ACEA	A3/B4
API Service Classification	SN and earlier specifications
BMW	Longlife-01
Benz	MB 229.3, MB 229.5
Porsche	A40
Renault	RN0700, RN0710
Volkswagen	VW 50200-Jul 05, VW 50500-May 10

JUSTAR J700F PLUS

5W-30
Engine Oil

API SN/CF
Fully Synthetic
GM Dexos2 Approved
ACEA C3



Product description

SINOPEC JUSTAR J700F Plus 5W-30 Engine Oil is a super-premium product formulated with Group III synthetic base oils and an advanced high-quality multifunctional additive package to provide effective protection to both turbocharged and naturally aspirated engines. Specially designed to meet the requirements of GM Dexos2 for light duty diesel engines; also suitable for gasoline engines that require an API SN quality oil.

Applications

SINOPEC JUSTAR J700F Plus 5W-30 Engine Oil is suitable for use in:

- Both turbocharged and naturally aspirated light duty diesel engines.
- Light duty diesel engines fitted with modern exhaust gas aftertreatment systems, e.g. diesel particulate filters (DPF), diesel oxidation catalysts (DOC) or selective catalytic reduction (SCR).
- Gasoline engines fitted with three-way catalytic converters (TWC).
- High performance cars and light vans with diesel or gasoline engines designed to meet Euro IV (ADR 80/02) or Euro V (ADR 80/03) emissions regulations.

Features and benefits

- Combination of synthetic base oils and antioxidant additive package extends oil life even under high temperature operating conditions.
- Excellent detergent and dispersant properties reduce the formation of sludge, keep the engine clean and reduce component wear.
- Special formulation protects diesel engines from harmful soot deposits, extending engine life.
- Excellent antiwear properties prevent energy loss through frictional wear and extend engine life.
- Low SAPs formulation protects expensive emission reduction systems and prolongs catalyst life.
- Ultra-low evaporation loss reduces oil consumption, extends oil change intervals and reduces exhaust emissions.
- Robust oil, resists degradation between oil changes and maintains optimum performance for longer.
- Outstanding shear stability ensures that the oil does not break down in severe service conditions, and so ensures optimum protection of engine components.
- Compatible with seal materials normally used in engines, to extend their life and prevent oil leakage under high engine pressure.
- Specifically designed to meet the performance requirements of GM Dexos2 for diesel engines.



Typical data

SINOPEC JUSTAR J700F Plus 5W-30 Engine Oil

SAE grade	5W-30
Kinematic viscosity, ASTM D 445	
cSt@40°C	70.9
cSt@100°C	11.9
Dynamic viscosity, CCS, ASTM D 5293	
cP@-30°C	6,350
High-temperature, high-shear viscosity (HTHS), ASTM D 4683	
cP@150°C	3.5
viscosity index, AXTM D 2270	165
NOACK volatility, ASTM D 5800	8.4
Sulfated ash, wt%, ASTM D 874	0.8
Total base number, mg KOH/g,ASTM D 2896	8.0
Pour point,°C, ASTM D 97	-36
Flash point (COC),°C, ASTM D 92	244
Density @ 15°C, kg/l, ASTM D 4052	0.850

These data are given as an indication of typical values and not as exact specifications.

Industry and OEM specifications

API Service Classification	Diesel: CF and earlier HDDEO specifications
	Petrol/Gasoline:SN,SM,SL and earlier specifications
ACEA	C3
ASTM	D4485-2010
BMW	Longlife 04
GM	Dexos2
MB	229.31/229.51
Volkswagen	502 00/505 00

JUSTAR J700F

5W-40
Engine Oil

API SN/CF

Fully Synthetic

VW 502 00/505 00 Approved



Product description

SINOPEC JUSTAR J700F 5W-40 Engine Oil is formulated with fully synthetic technology base oils and a multifunctional additive system for modern, high-performance petrol. It provides excellent oxidation resistance, deposit and wear protection, and low-temperature performance.

Applications

SINOPEC JUSTAR J700F 5W-40 Engine Oil is suitable for use in:

- Turbocharged and supercharged fuel-injected petrol engines.
- Naturally aspirated petrol engines in passenger cars and light commercial vehicles.
- High-performance passenger cars, racing cars and coaches equipped with multi-valves, turbochargers and direct-injection engines.

Features and benefits

- High-quality synthetic base oils in combination with an advanced additive system provide protection against engine sludge formation and build up, reducing oil thickening, thereby keeping the product in grade for longer and extending oil life.
- Provides excellent control of piston and ring deposits under high-temperature conditions.
- Excellent antiwear performance protects against engine wear and prolongs engine service life.
- Low oil evaporation loss leads to reduce oil consumption and exhaust emissions.
- Formulated to protect and extend the life of three-way catalytic converters.
- Low oil viscosity ensures good fluidity at low temperatures, reducing engine wear at start up and ensuring improved fuel efficiency.
- Excellent low-temperature start up performance and high temperature lubrication performance, suitable for all-weather use.
- Good elastomer compatibility ensures longer gasket and seal life, and prevents oil leakage.
- Approved as a service fill oil for mixed fleets.
- Energy conserving.



Typical data

SINOPEC JUSTAR J700F 5W-40 Engine Oil

SAE grade	5W-40
Kinematic viscosity, ASTM D 445	
cSt@ 100°C	15.27
Dynamic viscosity, CCS, ASTM D 5293, cP @ -30°C	6400
Mini-rotary viscometer (MRV), ASTM D 4684, cP @ -35°C	40000
Total base number, mg KOH/g, ASTM D 2896	9.66
Sulfated ash, wt%, ASTM D 874	1.10
Pour point, °C, ASTM D 97	-35
Flash point (COC), °C, ASTM D 92	200
Density@ 15°C, kg/l, ASTM D 4052	0.849

These data are given as an indication of typical values and not as exact specifications.

Industry and OEM specifications

API Service Classification	Petrol/Gasoline: SN, SM and earlier specifications Diesel: CF and earlier HDDEO specifications
ACEA	A3/B4-08
Porsche	A40
BMW	Longlife-01
GM	Opel GM-LL-B-025
MB	229.3
Renault	RN0700/0710
Volkswagen	501 01/502 00/505 00

JUSTAR J700F

5W-30/5W-20
Engine Oil

API SN
ILSAC GF-5
Fully Synthetic
GM Dexos1 Approved



Product description

SINOPEC JUSTAR J700F 5W-30 and J700F 5W-20 Engine Oil are super-premium products formulated with fully synthetic base oils and an advanced high-quality multifunctional additive package. Its ultra-cleaning formula protects engines from sludge, even when driven in modern stop-start traffic conditions, ensuring optimum engine performance. Specially designed to meet the GM Dexos1 requirements for gasoline engines (5W-20 and 5W-30).

Applications

SINOPEC JUSTAR J700F 5W-30 and 5W-20 Engine Oil is suitable for use in:

- Fuel-injected gasoline engines equipped with catalytic converters.
- Various high-performance passenger cars equipped with multi-valves, turbochargers and direct-injection engines, such as Buick, Chevrolet and Cadillac.
- Gasoline engines requiring a GM Dexos1, API SN/GF-5, SM/GF-4, SL/GF-3 or SJ/GF-2 quality oil.

Features and benefits

- Excellent detergent properties keep the engine clean and protect engine valves and turbochargers from deposits, ensuring optimum power output.
- Excellent oxidation stability protects against oil degradation and thickening, extending the time and mileage interval between oil changes and reducing maintenance costs.
- Outstanding antiwear performance reduces wear and prolongs engine service life.
- Excellent viscometric properties reduce engine friction and improve fuel economy and fuel economy retention.
- Catalyst compatibility ensures effective control of exhaust emissions.
- Resistance to aeration enables the optimum performance of fuel-saving devices such as variable valve timing.
- Excellent low temperature properties ensure engine protection, even at low temperature start-up.



Typical data

SINOPEC JUSTAR J700F 5W-30 and J700F 5W-20 Engine Oil

SAE grade	5W-20	5W-30
Kinematic viscosity, ASTM D 445		
cSt@40°C	46.76	59.72
cSt@100°C	8.34	10.36
High-temperature, high-shear viscosity (HTHS), ASTM D 4683		
cP@150°C	2.63	3.05
Dynamic viscosity, CCS, ASTM D 5293		
cP@-30°C	6,610	5,050
Viscosity index, ASTM D 2270	155	163
Total base number, mg KOH/g, ASTM D 2896	7.6	7.82
Pour point, °C, ASTM D 97	-45	-42
Flash point (COC), °C, ASTM D 92	230	233
Density@15°C, kg/l, ASTM D 4052	0.852	0.853

These data are given as an indication of typical values and not as exact specifications.

Industry and OEM specifications

API Service Classification	Petrol/Gasoline: SN, SM, SL and earlier specifications
ILSAC	GF-5, GF-4, GF-3 and earlier specifications
ASTM	D4485-2010
GM	Dexos1 (5W-20, 5W-30)

JUSTAR J600F *Premium*

5W-40
Engine Oil

API SM/CF

Fully Synthetic

ACEA C3

BMW LL-04

MB 229.31/51



Product description

SINOPEC JUSTAR J600F Premium 5W-40 Engine Oil is a stable, stay-in-grade, fully synthetic engine oil formulated with deeply hydrogenated base stocks and a unique additive system. Meeting various low SAPs specifications, and several OEM specifications, this product provides effective protection to both turbocharged and naturally aspirated gasoline and diesel engines. It is designed for vehicles fitted with a two-way catalytic converter (TWC) or the latest diesel after-treatment system (diesel particulate filter, DPF).

Applications

SINOPEC JUSTAR J600F Premium 5W-40 Engine Oil is suitable for use in:

- Turbocharged and naturally aspirated gasoline and diesel engines.
- Vehicles fitted with TWC or the latest diesel after-treatment system (e.g. DPF).
- High-performance car and light van diesel and gasoline engines.
- Engines that require an oil that meets EURO IV and EURO V emissions regulations.

Features and benefits

- Meets a wide range of specifications, and so reduces inventory costs.
- Formulated with high viscosity index, fully synthetic base stocks and advanced anti-oxidation additives, providing effective protection for engines under high temperature and prolonging their service life.
- Low SAPs formulation guarantees longer life of emission control devices such as TWC and DPF, and longer drain intervals, thus reducing maintenance costs.
- Effectively disperses ash and deposits, and inhibits the formation of sludge to keep engines clean, and reduce energy loss due to frictional wear.
- Ultra low vaporisation loss, reduces oil consumption and lowers exhaust emissions.
- Outstanding shear stability properties, with a minimum HTHS of 3.5 mPa.s, ensure the oil stays in grade for longer.
- Compatible with seal materials normally used in engines, so extends their life and prevents oil leakage.

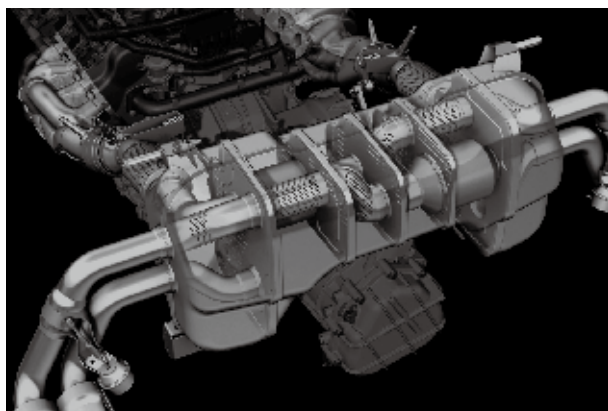

Typical data

SINOPEC JUSTAR J600F Premium 5W-40 Engine Oil

SAE grade	5W-40
Kinematic viscosity, ASTM D 445	
cSt@40°C	82.2
cSt@100°C	14.5
Viscosity index, ASTM D 2270	185
High-temperature, high-shear viscosity (HTHS), ASTM D 4683	
cP@150°C	3.75
Total base number, mg KOH/g, ASTM D 2896	7.6
Sulfated ash, wt%, ASTM D 874	0.77
Pour point, °C, ASTM D 97	-40
Flash point (COC), °C, ASTM D 92	230
Density@15°C, kg/l, ASTM D 4052	0.849

Industry and OEM specifications

ACEA	C3-08, A3/B3/B4
API	SM/CF
BMW	LL-04
Mercedez-Benz	MB 229.31/51
Porsche	A40
Volkswagen	VW 502 00/505 00

JUSTAR J600 *Premium*

10W-40 Engine Oil

API SN/CF Synthetic Technology BMW Longlife-01 VW 50200/50500



Product description

SINOPEC JUSTAR J600 Premium 10W-40 Engine Oil is a premium product formulated with fully synthetic base oils and high-quality multifunctional additive technology. It provides excellent oxidation resistance, deposit and wear protection, coupled with low-temperature performance for service in a wide range of modern, high-performance petrol and light duty diesel-powered vehicles.

Applications

SINOPEC JUSTAR J600 Premium 10W-40 Engine Oil is suitable for use in:

- Cars meet the Porsche, BMW, Benz, Volkswagen, Renault and other technical requirements;
- High-performance passenger cars, racing cars and coaches equipped with multi-valves, variable valve timing, turbochargers and direct-injection engines.
- Engine requiring oils of A3/B4 grade.

Features and benefits

- Using high-quality base oils, lasting protection and power for EFI engine with or without turbocharger.
- Balanced start up performance in low temperature and lubricating properties in high temperature.
- Excellent anti wear performance, reducing wear effectively to extend engine life.
- Superior oxidation stability and cleaning power to prevent deposits and sludge build-up.





Typical data

SINOPEC JUSTAR J600 Premium 10W-40 Engine Oil

SAE grade	10W-40
Kinematic viscosity, ASTM D 445	
cSt@100°C	14.17
Dynamic viscosity, CCS, ASTM D 5293	
cP@-25°C	3,700
Mini-rotary viscometer (MRV), ASTM D 4684	
cP@-30°C	18,000
High-temperature, high-shear viscosity (HTHS), ASTM D 4683	
cP@150°C	3.80
NOACK volatility, ASTM D 5800	10.4
Sulfated ash, wt%, ASTM D 874	1.1
Total base number, mg KOH/g, ASTM D 2896	10.1

These data are given as an indication of typical values and not as exact specifications.

Industry and OEM specifications

ACEA	A3/B4
API Service Classification	SL and earlier specifications
BMW	Longlife-01
BENZ	MB 229.3, MB 229.5
Porsche	A40
Renault	RN0700, RN0710
Volkswagen	VW 50200/50500, VW 50101/50500

JUSTAR J600

5W-30
Engine Oil

API SN
ILSAC GF-5
Synthetic Technology



Product description

SINOPEC JUSTAR J600 5W-30 Engine Oil is a premium product formulated with synthetic technology base oils and a high-quality multifunctional additive package. Its ultra-cleaning formula protects against engine sludge, even when driven in modern stop-start traffic conditions, ensuring optimum engine performance.

Applications

SINOPEC JUSTAR J600 5W-30 Engine Oil is suitable for use in:

- Gasoline engines equipped with catalytic converters.
- Direct-injection gasoline engines with multi-valves and turbochargers, such as those in high-performance passenger cars, racing cars and coaches.
- Gasoline engines that require an API SN/ILSAC GF-5 quality oil.

Features and benefits

- High viscosity index, synthetic technology base oils provide improved oxidation control compared to conventional oils, minimising the formation of sludge and deposits and reducing oil thickening. This ensures the oil stays in grade for longer and extends both oil and engine life.
- Excellent antiwear performance protects against engine wear and prolongs engine service life.
- The advanced low-ash additive system provides effective protection from deposits in gasoline engines equipped with turbochargers and electrically controlled high-pressure pump nozzles, and ensures optimum engine power output.
- Strict control of certain elements in the oil formulation ensures excellent catalyst compatibility and extends the life of three-way catalytic converters.
- Excellent temperature/viscosity characteristics ensure the protection of engine parts operating at both high and low temperatures.
- Low oil evaporation loss, a feature of the synthetic base oil, leads to improved fuel economy and reduces oil consumption, exhaust emissions and engine wear.
- Good elastomer compatibility ensures longer gasket and seal life.



Typical data

SINOPEC JUSTAR J600 5W-30 Engine Oil

SAE grade	5W-30
Kinematic viscosity, ASTM D 445	
cSt@40°C	61.56
cSt@100°C	10.37
Viscosity index, ASTM D 2270	158
Dynamic viscosity, CCS, ASTM D 5293	
cP@-30°C	5270
High-temperature, high-shear viscosity (HTHS), ASTM D 4683	
cP@150°C	2.96
NOACK volatility, ASTM D 5800	8.4
Sulfated ash, wt%, ASTM D 874	0.94
Total base number, mg KOH/g, ASTM D 2896	8.5
Pour point, °C, ASTM D 97	-43
Flash point (COC), °C, ASTM D 92	230
Density@15°C, kg/l, ASTM D 4052	0.843

These data are given as an indication of typical values and not as exact specifications.

Industry and OEM specifications

API Service Classification	Petrol/Gasoline: SN (Resource Conserving), SM, SL and earlier specifications
ASTM	D4485-2010
ILSAC	GF-5

JUSTAR J600

10W-30
Engine Oil

API SN
ILSAC GF-5
Synthetic Technology



Product description

SINOPEC JUSTAR J600 10W-30 Engine Oil(SN/GF-5) is formulated with high-quality synthetic technology base oils and a multifunctional additive system for modern, high-performance petrol and light duty diesel-powered vehicles. It provides excellent oxidation resistance, deposit and wear protection, low-temperature performance, and meets API SN and ILSAC GF-5 specification qualifying as an API Energy Conserving oil.

Applications

SINOPEC JUSTAR J600 10W-30 Engine Oil (SN/GF-5) is suitable for use in:

- Turbocharged and supercharged fuel-injected petrol engines.
- Turbocharged intercooled direct-injection diesel engines.
- Naturally aspirated petrol engines in passenger cars and light commercial vehicles.
- High-performance passenger cars, racing cars and coaches equipped with multi-valves, turbochargers and direct-injection engines.

Features and benefits

- High-quality synthetic technology base oils in combination with an advanced additive system provide protection against engine sludge formation and build up, reducing oil thickening, thereby keeping the product in grade for longer and extending oil life.
- Provides excellent control of piston and ring deposits under high-temperature conditions.
- Excellent antiwear performance protects against engine wear and prolongs engine service life.
- Low oil evaporation loss leads to oil consumption and exhaust emissions reduction.
- Formulated to protect and extend the life of three-way catalytic converters.
- Low oil viscosity ensures good fluidity at low temperatures, reducing engine wear at start up and ensuring improved fuel efficiency.
- Good elastomer compatibility ensures longer gasket and seal life, and prevents oil leakage.
- Approved as service fill oil for mixed fleets.
- Energy conserving.



Typical data

SINOPEC JUSTAR J600 10W-30 Engine Oil (SN/GF-5)	
AE grade	10W-30
Kinematic viscosity, ASTM D 445	
cSt@100°C	10.52
Dynamic viscosity, CCS, ASTM D 5293	
cP@-25°C	5300
High-temperature, high-shear viscosity (HTHS), ASTM D 4683	
cP@150°C	3.6
Pour point, °C, ASTM D 97	-35
Base Number, mg KOH g-1, ASTM D 2896	7.1
Phosphorus, wt%, ASTM D 4951	0.073
Sulfur, wt%, ASTM D 4951	0.226
Flash point (COC), °C, ASTM D 92	210

These data are given as an indication of typical values and not as exact specifications.

Industry and OEM specifications

API Service Classification	Petrol/Gasoline: SN, SM and earlier specifications
	Energy Conserving
	Diesel: CF and earlier HDDEO specifications
GB ¹	11122-2006 (CF)
ILSAC	GF-5
API Service Classification	Petrol/Gasoline: SN
	Energy Conserving

Note: 'GB' standards are the National Standards of the People's Republic of China.

JUSTAR J500

SM/GF-4 10W-30

SM/CF 10W-40

Engine Oil

Synthetic Technology



Product description

SINOPEC JUSTAR J500 10W-30 (SM/GF-4) and J500 10W-40 (SM/CF) Engine Oil are formulated with synthetic technology base oils and a high-quality multifunctional additive package. This multipurpose oil provides effective protection for gasoline or diesel engines, especially those operating at high ambient temperatures.

Applications

SINOPEC JUSTAR J500 10W-30 (SM/GF-4) and J500 10W-40 (SM/CF) Engine Oil are suitable for use in:

- A wide range of gasoline engines, especially for the major vehicle manufacturers, operating at high ambient temperatures.
- Direct and indirect injection diesel engines, which may be naturally aspirated, turbocharged or supercharged, working under high loads.
- Engines requiring an API SM/CF quality oil.

Features and benefits

- The high viscosity index oil protects gasoline and diesel engines operating at high ambient temperatures, and also ensures excellent performance is sustained at lower temperatures.
- The formulation contains detergents and dispersants, which prevent the formation of sludge and deposits, keeping the engine clean and reducing energy loss due to frictional wear.
- Good oxidation stability prevents oil degradation at high temperatures, and extends oil service life.
- Outstanding corrosion resistance, protects the engine and extends its life.
- Excellent antiwear properties prevent engine wear.
- Catalyst compatibility ensures the effective performance of three-way catalytic converters (TWC).
- Good elastomer compatibility ensures longer gasket and seal life, and prevents oil leakage.
- Suitable for mixed fleet use, reducing stock inventory costs.



Typical data

SINOPEC JUSTAR J500 10W-30 (SM/GF-4) and J500 10W-40 (SM/CF) Engine Oil

SAE grade	10W-30	10W-40
Kinematic viscosity, ASTM D 445		
cSt@40°C	77	
cSt@100°C	10.32	14.20
Viscosity index, ASTM D 2270	140	
Dynamic viscosity, CCS, ASTM D 5293		
cP@-25°C	4800	5200
Total base number, mg KOH/g, ASTM D 2896	6.70	6.70
Pour point, °C, ASTM D 97	-36	-35
Flash point (COC), °C, ASTM D 92	230	233
Density@15°C, kg/l, ASTM D 4052	0.866	0.872

These data are given as an indication of typical values and not as exact specifications.

Industry and OEM specifications

API Service Classification	Petrol/Gasoline: SM and earlier specifications
	Diesel: CF and earlier HDDEO specifications
GB ¹	11122-2006 (CF) 11121-2006 (SL)
ASTM	D4485-2010
Chrysler	Service fill oil for Chrysler 300C (in China) (10W-30)
Toyota	Factory fill oil for Toyota Camry (in China) (10W-30)

Note: 'GB' standards are the National Standards of the People's Republic of China.

JUSTAR J500

SM/CF 15W-40

SM/CF 20W-50

Engine Oil



Product description

SINOPEC JUSTAR J500 15W-40 and J500 20W-50 (SM/CF) Engine Oil are formulated with highly refined, hydrocracked base oils and a high-quality multifunctional additive package. These multipurpose oil provides effective protection for gasoline or diesel engines, especially those operating at high ambient temperatures.

Applications

SINOPEC JUSTAR J500 15W-40 and J500 20W-50 (SM/CF) Engine Oil are suitable for use in:

- A wide range of gasoline engines, especially for the major vehicle manufacturers, operating at high ambient temperatures.
- Direct and indirect injection diesel engines, which may be naturally aspirated, turbocharged or supercharged, working under high loads.
- Engines requiring an API SM/CF quality oil.

Features and benefits

- The high viscosity index oil protects gasoline and diesel engines operating at high ambient temperatures, and also ensures excellent performance is sustained at lower temperatures.
- The formulation contains detergents and dispersants, which prevent the formation of sludge and deposits, keeping the engine clean and reducing energy loss due to frictional wear.
- Good oxidation stability prevents oil degradation at high temperatures, and extends oil service life.
- Outstanding corrosion resistance, protects the engine and extends its life.
- Excellent antiwear properties prevent engine wear.
- Catalyst compatibility ensures the effective performance of three-way catalytic converters (TWC).
- Good elastomer compatibility ensures longer gasket and seal life and prevents oil leakage.
- Suitable for mixed fleet use, reducing stock inventory costs.





Typical data

SINOPEC JUSTAR J500 15W-40 and 20W-50 (SM/CF) Engine Oil

SAE grade	15W-40	20W-50
Kinematic viscosity, ASTM D 445		
cSt@40°C	119.3	175
cSt@100°C	15.5	18.8
Viscosity index, ASTM D 2270	137	121
Dynamic viscosity, CCS, ASTM D 5293		
cP@-15°C	-	8,000
cP@-20°C	6,100	-
Total base number, mg KOH/g, ASTM D 2896	6.70	6.70
Pour point, °C, ASTM D 97	-30	-24
Flash point (COC), °C, ASTM D 92	228	234
Density@15°C, kg/l, ASTM D 4052	0.871	0.881

These data are given as an indication of typical values and not as exact specifications.

Industry and OEM specifications

API Service Classification	Petrol/Gasoline: SM and earlier specifications
	Diesel: CF and earlier HDDEO specifications
GB ¹	11122-2006 (CF) 11121-2006 (SL)
ASTM	D4485-2010

Note: 'GB' standards are the National Standards of the People's Republic of China.

JUSTAR J500

SL/CF 20W-50

Engine Oil



Product description

SINOPEC JUSTAR J500 20W-50 Engine Oil(SL/CF) is formulated with highly refined base oils and a high-quality multifunctional additive system. This multipurpose oil can be used in many petrol and diesel passenger cars and light vehicles operating under normal or elevated ambient operating conditions, providing excellent engine protection.

Applications

SINOPEC JUSTAR J500 20W-50 Engine Oil (SL/CF) is suitable for use in:

- Petrol engines in present and earlier passenger cars, sport utility vehicles, vans and light trucks working under normal operating conditions and following vehicle manufacturers' recommended maintenance procedures.
- Direct and indirect injection diesel engines, which may be naturally aspirated, turbocharged or supercharged, working under high loads.
- Older vehicle engines require a heavier viscosity crankcase oil.

Features and benefits

- High-quality mineral base oils in combination with an advanced additive system provide protection against engine sludge formation and build up, reducing oil thickening, thereby keeping the product in grade for longer and extending oil life.
- Higher oil viscosity ensures good protection of metal surfaces at higher temperatures, protecting against engine wear.
- Low oil evaporation loss leads to reduce oil consumption and exhaust emissions.
- The formulation provides good control of piston and ring deposits; and excellent antiwear performance protects against engine wear, prolonging engine service life.
- Formulated to protect and extend the life of three-way catalytic converters.
- Good elastomer compatibility ensures longer gasket and seal life, and prevents oil leakage.





Typical data

Sinopec Justar J500 20W-50 Engine Oil (SL/CF)

SAE grade	20W-50
Kinematic viscosity, ASTM D 445	
cSt@40°C	172.6
cSt@100°C	18.00
Dynamic viscosity, CCS, ASTM D 5293	
cP@-15°C	6700
Viscosity index, ASTM D 2270	120
Total base number, mg KOH/g, ASTM D 2896	7.3
Pour point, °C, ASTM D 97	-25
Flash point (COC), °C, ASTM D 92	232
Density@15°C, kg/l, ASTM D 4052	0.881

These data are given as an indication of typical values and not as exact specifications.

Industry and OEM specifications

ACEA	A3/B3-04
API Service Classification	Petrol/Gasoline: SL and earlier specifications Diesel: CF and earlier HDDEO specifications
GB ¹	11121-2006 (SL) 11122-2006 (CF)
API Service Classification	Petrol/Gasoline: SL
Mercedes Benz	229.1

Note: 'GB' standards are the National Standards of the People's Republic of China.

Viscosity classification

SAE viscosity grades for engine oils SAE J300 revised 2009	SAE viscosity grade	Low-temperature (°C) cranking viscosity cP max	Low-temperature (°C) pumping viscosity cP max with no yield stress	Low-shear-rate kinematic viscosity (cSt) at 100°C min max	High-shear-rate viscosity (cP) at 150°C min
	0W	6200 at -35	60000 at -40	3.8	
	5W	6600 at -30	60000 at -35	3.8	
	10W	7000 at -25	60000 at -30	4.1	
	15W	7000 at -20	60000 at -25	5.6	
	20W	9500 at -15	60000 at -20	5.6	
	25W	13000 at -10	60000 at -15	9.3	
	20			5.6	<9.3 2.6
	30			9.3	<12.5 2.9
	40			12.5	<16.3 3.5*
	40			12.5	<16.3 3.7**
	50			16.3	<21.9 3.7
	60			21.9	<26.1 3.7

* 0W-40, 5W-40 and 10W-40

** 15W-40, 20W-40, 25W-40 and 40

Automotive gear lubricant viscosity classification SAE J306 revised October 2005	SAE viscosity grade	Maximum temperature for viscosity of 150 000 cP, °C	Kinematic viscosity at 100°C, cSt min max	
	70W	-55	4.1	
	75W	-40	4.1	
	80W	-26	7.0	
	85W	-12	11.0	
	80		7.0	<11.0
	85		11.0	<13.5
	90		13.5	<18.5
	110		18.5	<24.0
	140		24.0	<32.5
	190		32.5	<41.0
	250		41.0	

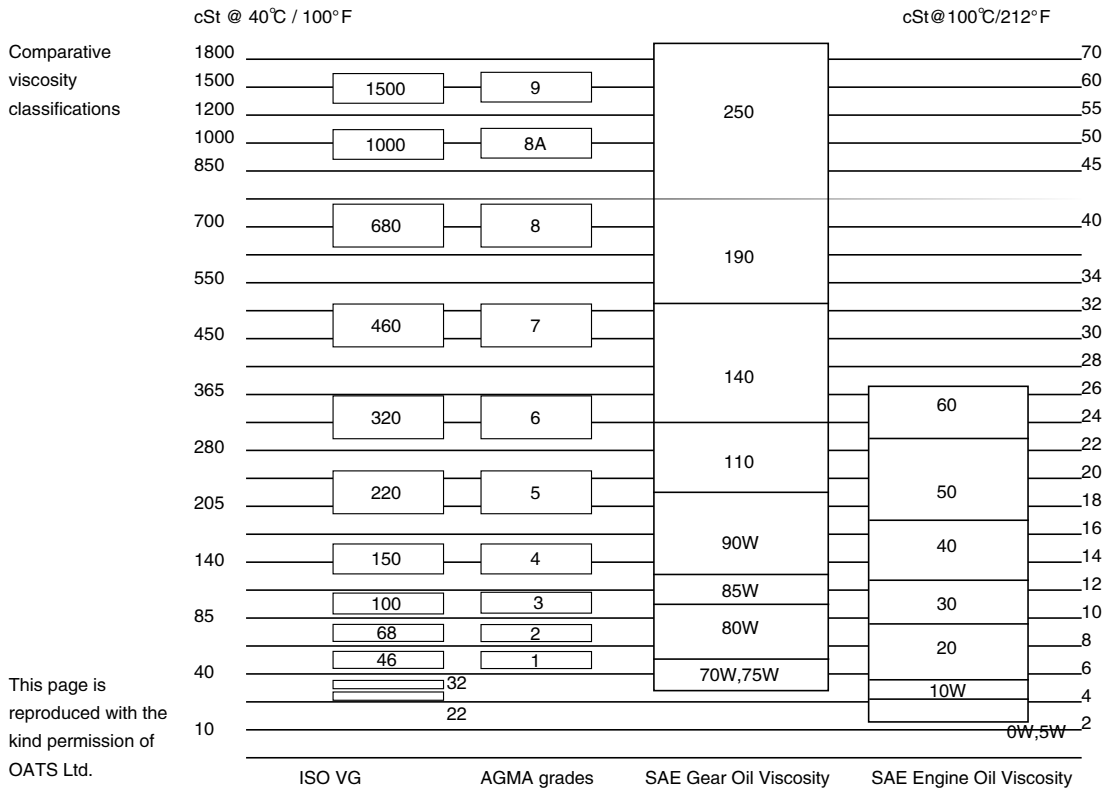

This page is reproduced with the kind permission of OATS Ltd.
© OATS 2013

SINOPEC

LUBRICANTS

**NEW FACTORY
NEW PACKAGE
NEW MILESTONE**



Old Packages



**NEW
ARRIVALS**

Performance in motion

Sinopec Lubricant (Singapore) Pte Ltd is located at Tuas South Singapore, covering an area of 242,811 square meters. The initial production capacity of the company is 100,000 metric tons per year, and it will produce high-grade lubricants and greases to meet the increasing regional market demands.

Sinopec Lubricant (Singapore) Pte Ltd is the key to the global expansion of Sinopec. It will be functioning as the regional hub, the important production center, and the service and logistics center, enabling Sinopec to better serve the customers in **Australia, South East Asia, the Middle East, Africa and South America.**



SINOPEC



SINOPEC LUBRICANT CO., LTD.

Add: No. 6, West Road of Arring Zhuang, Haidian District,
Beijing P.R. China P.C. 100085
Tel: 0086-10-82949773 62846404 Fax: 0086-10-82416960
Email: guoshilube@sinopec.com
http://www.sinolube.sinopec.com

Service guide

Customers Enquires:

If you need help, please call the service hotline at:

400-810-9886

We will provide you with services like "customer consulting", "opinions and suggestions handling", "customer complaint handling" and "e-commerce"; Click the official website (<http://sinolube.taobao.com>) and visit the "Official Flagship Store of SinopecLubricant at Taobao" set up by SinopecLubricant at Taobao.com for easy and convenient online shopping. Please visit the website (www.sinolube.com) for more information.

ACCURACY OF INFORMATION

Data provided in this brochure is typical and subject to change as a result of continuing product research and development. The information given was correct at the time of printing. The typical values given are subject to variations in the testing procedures and the manufacturing process may also result in slight variations. Sinopec guarantees that its lubricants meet any industry and OEM specifications referred to this data sheet.

Sinopec cannot be held responsible for any deterioration in the product due to incorrect storage or handling. Information on best practice is available from your local distributor.

PRODUCT AND ENVIRONMENTAL SAFETY

The products should not cause any health problems when used in the applications suggested and when the guidance provided in the Material Safety Data Sheet (MSDS) is followed. Please consult the MSDS for more detailed advice on handling; MSDSs are available from your local distributor. Do not use the product in applications other than those suggested.

As with all products, please take care to avoid environmental contamination when disposing of this product. Used oil should be sent for reclamation/recycling or, if not possible, must be disposed of according to relevant government/authority regulations. The SINOPEC trademark is registered and protected.

SINOPEC

SINOPEC LUBRICANT CO., LTD.

Address: No.6, Anningzhuang West Road, Haidian District, Beijing

Postcode: 100085

Website: <http://english.sinolube.com>